

MORRISON PRODUCTS, INC.

Manufacturers of Air Moving Equipment

MODEL SEF-E EXHAUST FAN (115V/60 HZ)

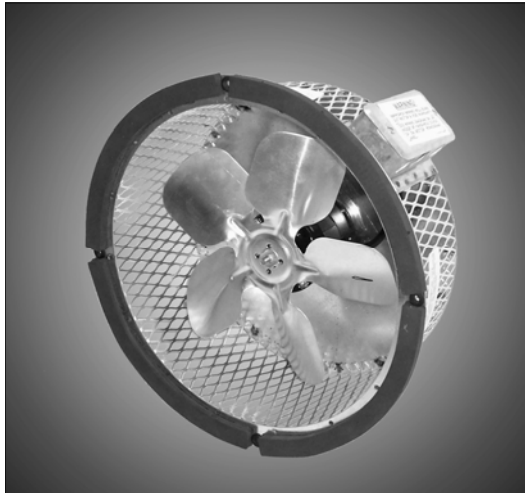

SPEED TAP	CFM @ FREE AIR	*SOUND PRESSURE (dBA)	WATTS
LOW	175	40.2	39.2
HIGH	323	57.6	64.1

*SOUND PRESSURE MEASURED AT 0.75 METERS AWAY FROM DISCHARGE CENTER

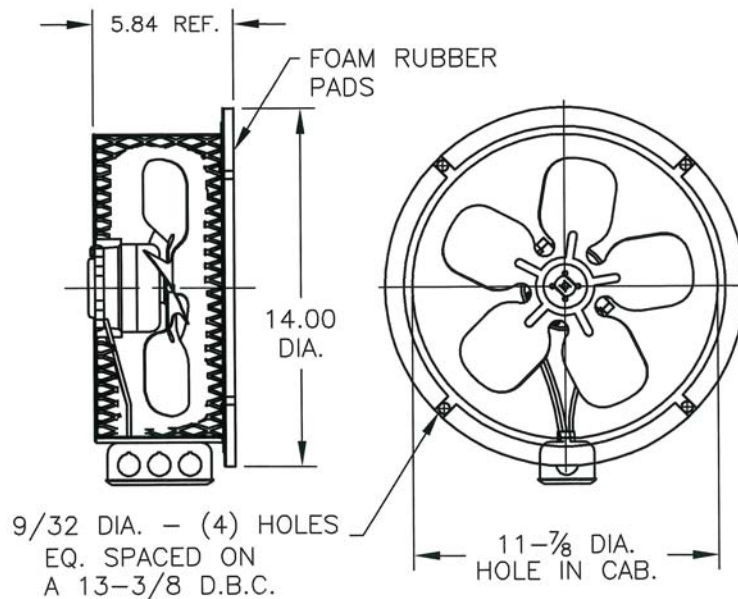

ASSY NAME	2 SPD BLWR
PART NUMBER	06-02016
MOTOR P/N	96-07303
H.P.	16.4 WATT
RPM	1450
FLA	.77
VOLTS	115
PHASE	SINGLE
CYCLE	60
CAP.	NONE

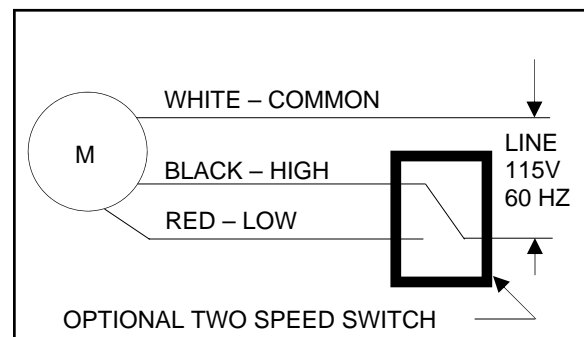

WIRING DIAGRAM

MORRISON PRODUCTS, INC.

Manufacturers of Air Moving Equipment

MODEL SEF-E EXHAUST FAN (115V/60 HZ)

SAMPLE SPECIFICATION:

Elevator Cab Exhaust Fan shall be a 2 speed, Propeller Exhaust Fan, Model SEF-E, Part number 06-02016, manufactured by Morrison Products, Inc. The high speed rating shall equal or exceed 320 cubic feet per minute, at a maximum of 65 watts. The corresponding sound pressure level at .75 meters from the fan shall not exceed 58 dBA. The blower motor will be permanently lubricated and UL and CSA approved.

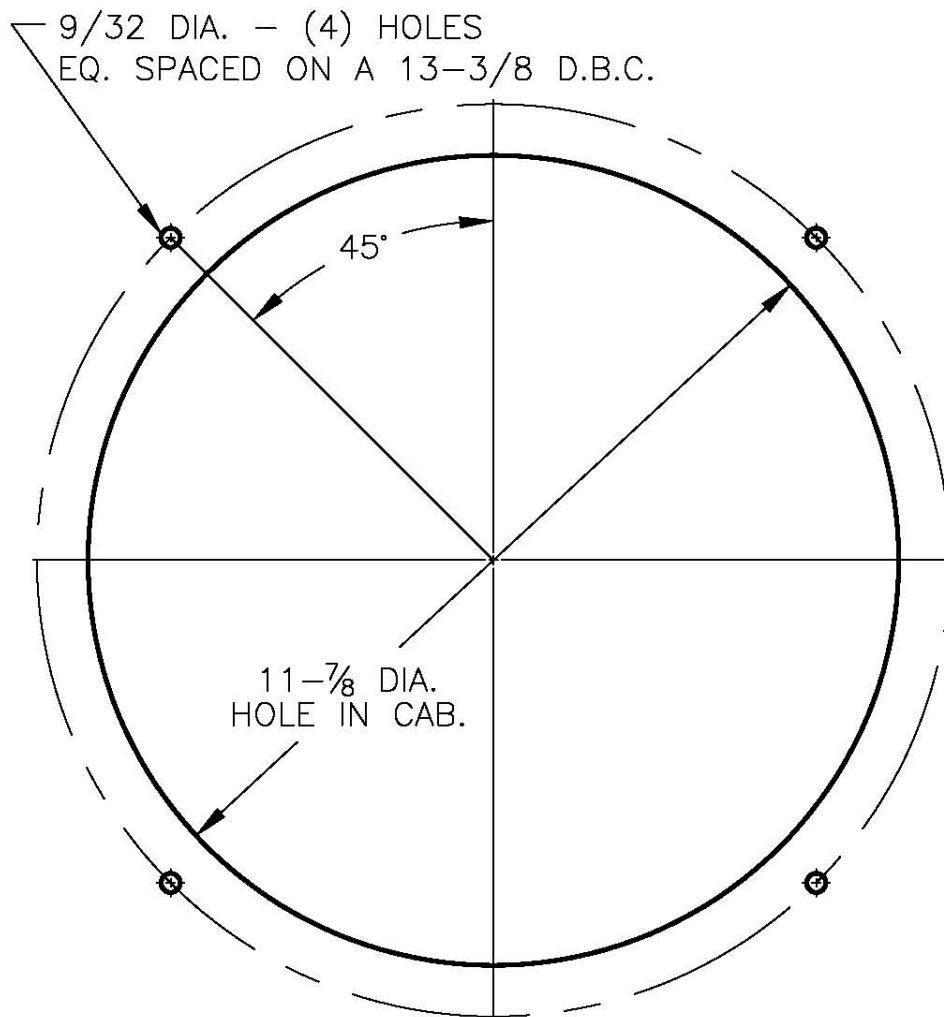

TEMPLATE FOR MOUNTING HOLE LOCATIONS
AND EXHAUST HOLE OPENING FOR MODEL "SEF-E"
ELEVATOR CAB EXHAUST UNIT